



The Refinements, 18 Thorpe Hall Mansions, Eaton Rise, London, W5 2HB
Tel: +44 (0)7806 564386 or +44 (0)7957 535535
www.therefinements.com therefinements@gmail.com

TECHNICAL RIDER

This rider consists of two pages

Thank you for considering The Refinements for your event. We pride ourselves on our friendliness and professionalism, and will do everything we can to ensure that your night is a complete success. Please contact us if you have any queries in advance of the gig.

We are completely self-contained band and normally play using our own backline, PA, stage and dancefloor lighting. However some clients prefer to provide their own PA and/or backline. The following requirements are ideal for a venue with up to 250 guests:

BACKLINE

Lead vocal mic (Shure SM58) plus 2-piece mic stand
3 backing vocal mics (3 x Shure SM58) plus 2-piece mic stands
Bass amp (350W RMS Peavey combo or equivalent) plus Shure PG57 mic as pickup
Guitar amp (100W RMS Marshall combo or equivalent) plus Shure PG57 mic as pickup
5 piece drum kit - Mapex/Pearl/Yamaha or equivalent quality (we will provide cymbals/snare/kick pedal)
Full set of drum mics (1 x snare mic, 3 x tom mics, 1 x kick drum mic, 2 x condenser overheads)

All drum hardware must be in good condition. Mics and amps must be in full working order with no unwanted distortion.

PA

Minimum 1.5kW power-amp system required with 16 XLR input channels
4 x Active Stage Monitors (100W minimum)

The PA system must be capable of providing a clean and undistorted 110dB RMS to the mixing desk with powerful and feedback-proof monitoring.

PA inputs are as follows:

Lead vocals (1 x XLR)
Backing vocals (3 x XLR)
Keyboard (2 x XLR from DI box)
Saxophone (1 x XLR from pre-amp)
Bass amp (1 x XLR from mic)
Guitar amp (1 x XLR from mic)
Drums (7 x XLR from mics)

STAGE LIGHTING

Minimum 8 x adjustable PAR56/LED equivalent lights plus DMX controller with suitable pre-sets (if you require the band to operate the stage lighting).

STAGE PLAN

The following is our normal stage plan. This can be adjusted according to the physical characteristics of the venue. Our minimum requirement is for a clean, dry and stable surface of at least 4m x 5m size.

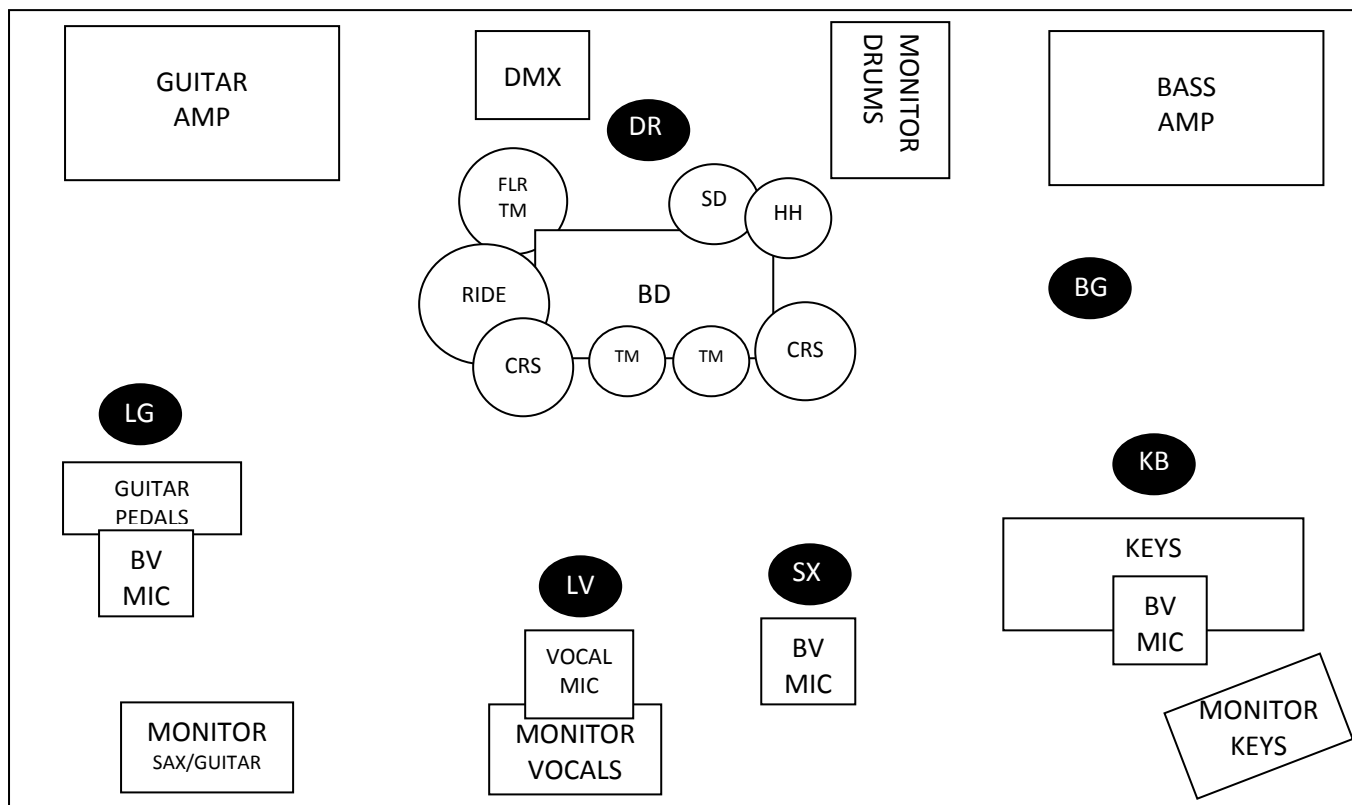

Key:

Musicians

BG = bass guitarist
DR = drummer
KB = keyboard player
LG = lead guitarist
SX = saxophone player
LV = lead vocalist

Drums

BD = bass drum
CRS = crash cymbal
FLR TM = floor tom
HH = hi-hat
RIDE = ride cymbal
SD = snare drum
TM = rack tom

Other

BV = backing vocals
DMX = lighting controller

PERSONAL RIDER

A personal rider will be agreed as part of the Contract To Play.

Typically we ask that the following are provided as a minimum to ensure the comfort of the performers:

- One round (6 x pints) tap water with ice (ON STAGE)
- One round (6 x pints) alcoholic or soft drinks from the bar (BACKSTAGE)
- A meal (e.g. sandwiches and snacks) suitable for six people
- A reasonable size backstage area in which the performers can get changed and relax between sets (please note: The toilets of the venue are not a suitable changing area. Any other private room or area is acceptable).